



LIMO | 6 PASSENGER 

CRUISER | 4 PASSENGER 



USER MANUAL

SAFETY GUIDE & INSTRUCTIONS

Thank you for your purchase!

For the best user experience, please read through this **User Manual** carefully and follow the vehicle's safety instructions.

Phone: +1-888-325-1596

Email: sales@vcarts.com or contact@vcarts.com

Address:
30798 Kingsland Blvd.,
BLDG B / STE 200
Brookshire, TX 77423

sales@vcarts.com

www.vcarts.com

Fully Electric • Road Ready

TABLE OF CONTENTS

Introduction	3
Notices	4
Liability & Vehicle Design Changes	4
Vehicle Modifications	4
Safety Information	4
Vehicle Controls	5
11" Touch Screen Display	6
Instrument interface	6
Main Menu/Multimedia	6
Radio	6
EQ Setup.....	7
Bluetooth / Bluetooth Music	8
Contact person.....	9
USB.....	11
ONBOARD CHARGER	11
SPEC SHEETS	12
The Badger 1 PASSENGER	12
F-SERIES F4 4 Passenger	14
CRUISER 4 PASSENGER CRUISER 4 PASSENGER	15
LIMO 6 Passenger	16
ESeries 4 & 6 PASSENGER	17
The Golf 2 PASSENGER	18
AC Electrical Cord And Plug	19
ELECTRICAL CORD	19
ELECTRICAL PLUGS AND RECEPTICALS	19
New Cart Initial Maintenance	19
Charging Instructions	20
Status Indicator Lights	21
DAILY PRE-OPERATIONAL SAFETY AND PERFORMANCE CHECKS	22
RULES OF SAFE OPERATION	23
VEHICLE PERFORMANCE INSPECTION	23
MOTOR START	24
TURN OFF MOTOR	25
Vehicle Maintenance	25

Electronic Motor: 25

Troubleshooting guide: 25

Controller 25

Troubleshooting guide 26

Brake System 26

Lubrication 26

BATTERY MAINTENANCE..... 27

Extended Storage.....**28**

 Extended Storage Preperation 28

RETURN TO SERVICE FROM EXTENDED STORAGE 29

Transport Disclaimer/ Instructions.....**29**

INCLINE Disclaimer **30**

INTRODUCTION

This kind of golf cart, equipped with a lithium-ion battery, is low maintenance, environmentally friendly, and road-ready, specially designed for use on the golf course or paved streets. It also can be used in vacation villas, apartment complexes, hotels, tourist spots, family outings, resorts, etc.

Our versatile golf cars are an ideal off-road electric car with excellent performance, sleek design, luxurious, and delicate internal decoration as well as comfortable and safe ride. Read, understand, and obey the technical content in this manual to protect your investment and provide years of reliable vehicle operation.

Read, understand, and obey all instructions and safety precautions in this manual to prevent the risk of personal injury or property damage.

VCart[®] recommends owners that rent, or loan vehicles make sure operators read this manual before vehicle operation.

VCart[®] recommends owners register their vehicles immediately after purchase. The previous owner must include this manual with the vehicle when sold to a new owner. Registration of the vehicle will make sure VCart[®] is able to communicate necessary information directly to owners. Send your name, address, and serial number of the vehicle to:



sales@vcarts.com

NOTICES

Liability & Vehicle Design Changes

VCarts® is not liable for errors in this manual or for incidental or consequential damages that result from the use of the material in this manual.

VCarts® reserves the right to make design changes to vehicles without obligation to make these changes on units previously sold.

This manual is the original instructions provided by the manufacturer if in English. This manual is a translation of the original instructions if in any language other than English.

Vehicle Modifications

DANGER

Modifications or changes to the vehicle that affect the occupant retention, electrical system, stability, or handling of the vehicle, or increases the maximum vehicle speed can cause serious personal injury or death.

NOTICE

We recommend additions, add-ons, or modifications to the vehicle must be done by a professional and must not compromise compliance with state or federal regulations.

Do not install non-VCarts® approved accessories or change the vehicle function to increased speed or power. Modifications or installation of non-VCarts® approved accessories could cause a substantial safety hazard and increase the risk of bodily injury or property damage.

Modifications may void the warranty. Refer to the warranty for more details.

The performance characteristics of the vehicle may change because of the addition of some accessories, including (but not limited to) lift kits, tires, or large racks. Use only VCarts® approved accessories. Know the function of the accessories and their effects on the vehicle.

SAFETY INFORMATION

ALWAYS:

- Use the vehicle in a responsible manner and maintain the vehicle in safe operating condition
- Read and observe all warnings and operation instruction labels affixed to the vehicle
- Follow all safety rules established in the area where the vehicle is being operated
- Leave the vehicle when there is a risk of lightning
- Reduce speed to compensate for poor terrain or conditions
- Apply brakes to control speed on steep grades
- Maintain adequate distance between vehicles
- Reduce speed in wet areas
- Use extreme caution when approaching sharp or blind turns
- Use extreme caution when driving over loose terrain
- Use extreme caution in areas where pedestrians are present

VEHICLE CONTROLS

- 01 Hazard Lights
- 02 Forward, Neutral Reverse Switch
- 03 Brake Pedal
- 04 Parking Pedal Lock
- 05 11" Touch Screen Display
- 06 2 Cup Holders X2
- 07 Push Button Ignition
- 08 USB & USB-C Ports
- 09 Locking Glove Box X2



Push Button Ignition: Master switch of the Electric System is a push button is a large circular button at the center of the dash, below the hazard switch, once pushed, accessories such as lights, horns, radio, USB ports, and control system will be turned on. When the key is pushed again, the electric power will be turned off.

Forward, Neutral, Reverse Switch: This is a 3-position switch; pressing down the upper part means forward while pressing down the lower part means backward.

Brake Pedal: Used in deceleration or parking. Electric brake is automatically triggered when the pedal has fully lifted.

Parking Pedal: Located at the top of the brake pedal, this small rectangular pedal is used in breaking for parking. Press the pedal all the way down. Depress all the way down, until a clicking (parking/lock noise) stops and resistance is felt.

Locking Glove Box: Control the driving direction by turning the wheel to the corresponding direction.

11" Touch Screen Display: Touch screen allows monitoring of power levels, vehicle speed, battery power, vehicle direction (D or R), Bluetooth, Apple CarPlay, Android Auto, USB, Radio, and more. [See "11in Touch Screen Display" section for more details.](#)

Forward Backward Switch: Used for controlling the speed, it should be stepped on slowly. The car speeds up with the gradual stepping down. The car reaches its full speed when the pedal is stepped down totally and slows down with the lifting of the pedal.

11" TOUCH SCREEN DISPLAY

INSTRUMENT INTERFACE

Labels for the instrument interface include: Current (0.0A), Left turn signal, Full beam, Low beam, Ready lamp, Lamplet, Rear fog lamp, Right turn signal, Motor temperature (30°C), Speed (0 km/h), Voltage (24.0V), Gear, Subtotal mileage, Trip (0215.8 km), ODO (003548 km), Multimedia UI entry, Total mileage, Charging light, SOC, and Parking.

On-screen keystroke definition:

- Logo icon
- Sleep key
- Home button
- Back key
- Volume plus key
- Volume minus key

When you add or subtract volume, the volume icon will appear



MAIN MENU/MULTIMEDIA

Power-on interface, home button/car icon, enter Main menu

Labels for the main menu include: Title name, Volume (17), USB flash drive status, Time (08:25), Bluetooth Status, Backlight, Return Instrument UI, and Return to upper level.

Icons on the main menu include: Radio, BT Music, USB, PhoneLink, and Setup.

Icons on Main Menu

- Volume display, volume range: 0-40
- Udisc icon
- Bluetooth icon

Full bright /Semi-bright /Screen off

Touch the icon to change the backlight

Instrument icon

Tap the instrument icon to return to the instrument interface.

RADIO

Touch the icon to enter the RADIO:



Search the channel forward



Search the channel backward



Slide EQ can adjust the frequency, listen to the frequency you like.



DX/LOC, Indicates receipt Far/ Close-range signal radio station



Search channel

Touch the search icon, search for the radio channel, and the searched radio channel number will be displayed on the screen.

Click thru to select the channel you like.

EQ SETUP



Click the sound effect icon and the sound effect setting interface will appear.

You can set the sound effect style according to your preference. And Hertz size, as shown in the figure.



Click, you can set the left and right sound channels

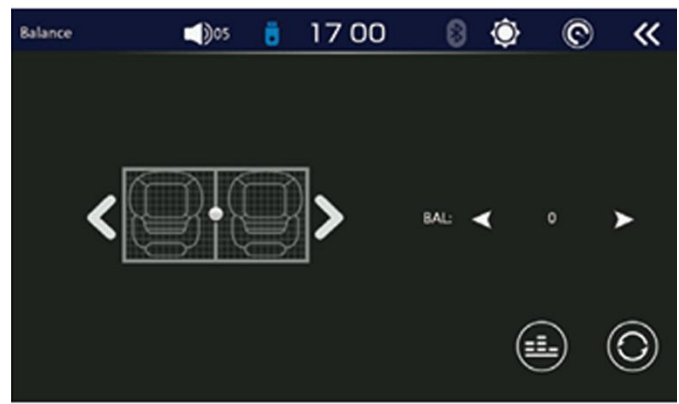
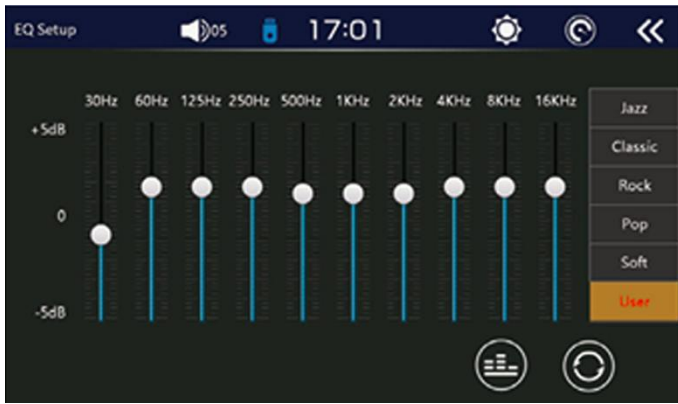

BLUETOOTH / BLUETOOTH MUSIC

Touch the icon to enter Bluetooth

Connect through the Bluetooth of the mobile phone,

Click to pair, display the Bluetooth name.

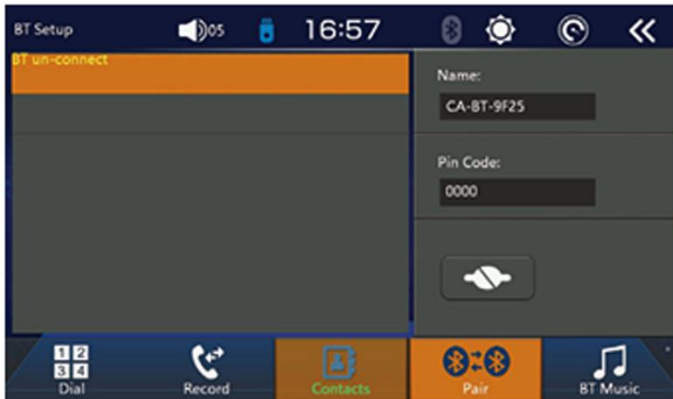
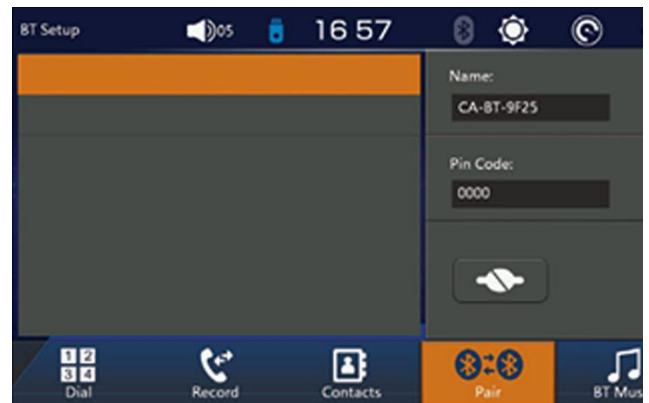

When the connection is successful, the yellow area shows the Bluetooth name of the mobile phone, as shown in the figure.

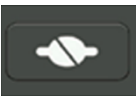

Note that you can click the connection icon to disconnect the Bluetooth connection state:

Bluetooth Music

Click Bluetooth music to display the playing status of Bluetooth music, the name of the song, and the name of the singer, as shown in the figure

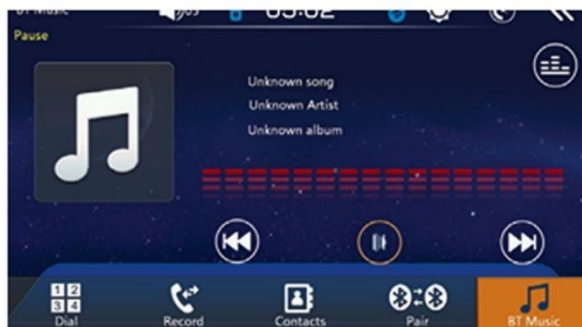

Click the pause button to play Bluetooth music.



Press to jump to the previous song.



Press to jump to the previous song.

CONTACT PERSON



Contacts

Click the contact icon



Record

Click Call record

Can See the call record interface, as shown in the figure



Enter the interface, and you can click the download icon, download the address book in the mobile phone

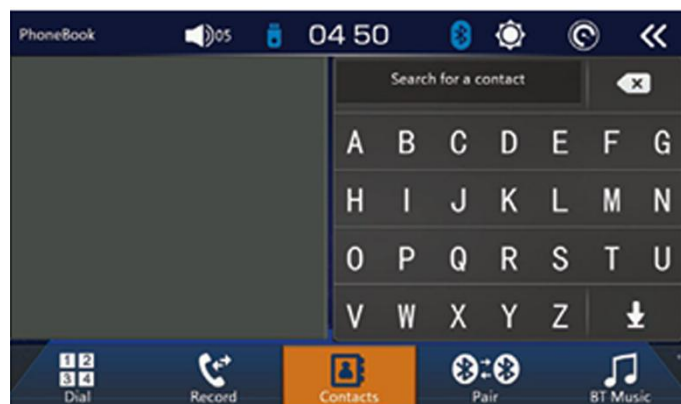
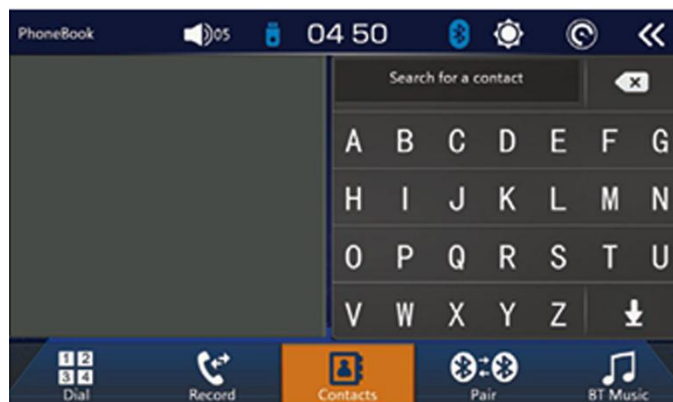



Click to dial Enter the dial-up interface

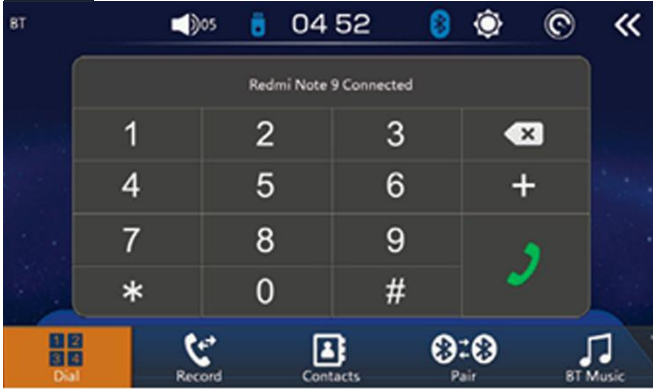

Click to dial Enter the dial-up interface Delete the number key



Indicates that the country code is omitted.



Dial the phone button

Display interface in the call



Call Bluetooth/mobile phone sound switching Keyboard



When you need to enter the number during the call, you can click the keyboard.



Hang up the call button



Key to answer the call

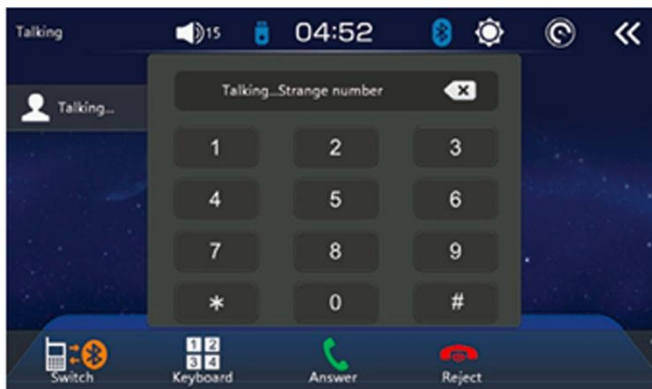

USB



Insert the U Disk, the USB icon will be displayed at the top of the screen, the color is blue



Music

Click on the music Symbol Icon, display music information on the screen, slide/touch the screen to select music



Select the song you want to listen to and enter the music interface, as shown in the figure



Insert the USB into the play mode, and the screen shows the name of the singer/song and the album.

Plug in the USB and enter the playback mode. Play the first song by default. Touch the screen and swipe down to select the song, and you can view the songs in the USB.



Progress bar: Display the length of the song, the playback progress, and the playback time

ONBOARD CHARGER



The VCart[®] comes equipped with a Lithium Battery Charger installed and located on the passenger side of the vehicle under the folding seat.

DANGER

A battery charger, cord, plug, or vehicle charger receptacle that has damage or a bad electrical connection can cause a fire, property damage, serious personal injury, or death. Do not connect the damaged battery charger to an ac power source. Do not try to repair the battery charger, cord, plug, or vehicle charger receptacle. Speak with your local dealer or distributor for repairs.

WARNING

Incorrect connection of the charging power cord can cause a fire or an electrical shock. Do not use an adapter to connect the cord into power source. Connect the power cord directly to an approved power source.

Connection of the charging power cord to an incorrect receptacle can cause a fire, electrical shock, property damage, serious personal injury, or death. Connect the power cord to an approved power source and receptacle.

Liquid on the battery charger can cause property damage, electrical shock, serious personal injury, or death. Do not let the battery charger become wet. Keep the battery charger dry.



SPEC SHEETS

THE BADGER | 1 PASSENGER

GO ANYWHERE



Dimensions (feet & inches)	5'8" L x 3'5" W x 4'8.5" H
Ground Clearance (inches)	6.5"
Max Forward Speed (miles per hour)	Up to 24 mph*
Weight (pounds)	414lbs
Max Load Capacity (pounds)	390lbs
Max Towing Capacity (pounds)	500lbs
Max Incline	Up to 45°
Running Distance (miles)	Up to 31mi*
Off Road Tires (inches)	21 x 7 - 10
Suspension	4 Wheel – Independent
Brakes	4 Wheel Disc Brakes
Battery	60V/50A High Quality Lithium
Motor	4 Brushless 60V/1500W, 60V/6000W
Charger	120V

View more at VCARTS.COM



BADGER
VIEW PAGE

ATTACHMENTS



Up to 45° Incline



Turning Radius
8.2' (2.5m)



5-6hr Charging
Time (60V/50A)



Independent
Suspension



Cart Trailer Ready
(Rear-Hitch Included)



Rear Basket
Attachment



1 Golf Bag
Attachment



Gun Rack
Attachment



Cup Holder
Attachment

*Speed/Range may vary depending on passenger load, cargo, terrain, & driving conditions.

© 2021-2025 VCARTS®, INC. USA

GO BOLDLY



Dimensions (feet & inches)	9'9" L x 4'6" W x 6'7" H
Ground Clearance (feet & inches)	1'3"
Max Forward Speed (miles per hour)	Up to 25 mph
Weight (pounds)	1,380lbs
Max Load Capacity (pounds)	960lbs
Max Incline	Up to 20°
Motor	5kW
Running Distance (miles)	Up to 35 mi* or Up To 100 mi**
Black Rim Tires (metric & inches)	225 / 50R 14
Suspension	Independent & Coilover Shocks
Frame / Chassis	Zinc-Plated Powder Coated

COLORS



*Range may vary depending on passenger load, cargo, terrain, & driving conditions.

GO EXPLORE



Dimensions (feet & inches)	9'8" L x 4'6" W x 6'8" H
Ground Clearance (feet & inches)	1'3"
Max Forward Speed (miles per hour)	Up to 25 mph
Weight (pounds)	1,125lbs
Max Load Capacity (pounds)	800lbs
Max Incline	Up to 20°
Motor	5kW
Running Distance (miles)	Up to 35 mi*
Off Road Tires (inches)	23 x 10 - 14
Suspension	Independent (4 Wheel)
Frame / Chassis	Zinc-Plated Powder Coated

COLORS



*Range may vary depending on passenger load, cargo, terrain, & driving conditions.

© 2021-2025 VCARTS®, INC. USA

GO TOGETHER



Dimensions (feet & inches)	12' L x 4'6" W x 6'8" H
Ground Clearance (feet & inches)	1'3"
Max Forward Speed (miles per hour)	Up to 25 mph
Weight (pounds)	1,305lbs
Max Load Capacity (pounds)	1,100lbs
Max Incline	Up to 20°
Motor	5kW
Running Distance (miles)	Up to 35 mi*
Off Road Tires (inches)	23 x 10 - 14
Suspension	Independent & Coil Spring
Frame / Chassis	Zinc Plated Powder Coated

COLORS



LIMO - 6
VIEW PAGE >>

*Range may vary depending on passenger load, cargo, terrain, & driving conditions.

© 2021-2025 VCARTS®, INC. USA

GO DISCOVER



Dimensions (feet & inches)	11'9" L x 3'10" W x 6'3" H	9'3" L x 3'10" W x 6'3" H
Ground Clearance (feet & inches)	1'3"	1'3"
Max Forward Speed (miles per hour)	Up to 25 mph	Up to 25 mph
Weight (pounds)	1,175lbs	1,041lbs
Max Load Capacity (pounds)	960lbs	800lbs
Max Incline	Up to 20°	Up to 20°
Motor	5kW	5kW
Running Distance (miles)	Up to 35 mi*	Up to 35 mi*
Off Road Tires (metric & inches)	225 / 50R 12	225 / 50R 12
Suspension	Leaf Spring	Leaf Spring
Frame / Chassis	Zinc Plated Powder Coated	Zinc Plated Powder Coated

COLORS



*Range may vary depending on passenger load, cargo, terrain, & driving conditions.

GO PLAY



Dimensions (feet & inches)	7'9" L x 3'8" W x 6'5" H
Ground Clearance (inches)	12"
Max Forward Speed (miles per hour)	Up to 25 mph
Weight (pounds)	960lbs
Max Load Capacity (pounds)	800lbs
Max Incline	Up to 20°
Motor	5kW
Running Distance (miles)	Up to 35 mi*
Turf Tires (metric & inches)	215 / 50 - 12
Suspension	Leaf Spring
Frame / Chassis	Zinc Plated Powder Coated

COLORS

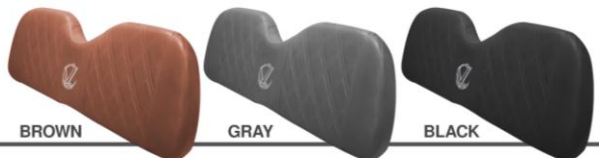

THE GOLF
VIEW PAGE >>



*Range may vary depending on passenger load, cargo, terrain, & driving conditions.

© 2021-2025 VCARTS®, INC. USA

AC ELECTRICAL CORD AND PLUG



The AC electric cord has an equipment-grounding conductor and grounding type plug. The AC plug must be connected to a correctly rated ground fault circuit interrupter (GFCI) receptacle with arc flash protection. The receptacle must be installed and grounded in accordance with the National Electrical Code, local codes, and local ordinances.

- The extension cord must accept a three-prong plug.
- The extension cord must be as short as possible and not exceed 12 ft (3.7 m).
- Make sure that cords will not be stepped on, tripped over, or subject to damage or stress.

ELECTRICAL CORD

Examine electrical cords for wear and damage before use. Immediately replace electrical cords for:

- Cracks
- Cuts
- Frayed wiring
- Insulation damage
- Loose connections
- Splices

ELECTRICAL PLUGS AND RECEPTICALS

Do not try to repair the AC CORD PLUG or PINS. If the plug pins are bent, speak with your local dealer or distributor for repairs.

Examine electrical plugs for wear and damage before use. Immediately replace electrical plugs for:

- Corrosion
- Cracks
- Loose connections
- Missing pins
- Worn pins

NEW CART INITIAL MAINTENANCE

The procedure of running in should be done to the parts of the motor before it works with the maximum load to guarantee the reliability of the car and to extend its life. The period of “running in” is one month and the procedure should be undergone as follows:

- Check the levels of oil, carefully before running in and fill them as requested.
- Check tire pressure. The tire should be “23 x 10 - 14” with the air pressure of 200 -250 kPa
- If possible, avoid driving on roads in poor conditions.
- Check and fasten the fixture parts of each connection regularly.
- Check the parts on the chassis regularly. Verify all parts are working properly.

- Add and charge grease to the rear power assembly as requested in the manual.
- The wear condition of the brake pads must be checked once every 3 months. Replace if any brake pad deviates or fails to work.
- Check if any fixture part of the electrical system especially the main circuit becomes loose once every three months to make sure they are in good contact; at the same time, check the contact points of the contactors and remedy the defects found; blow off dust with low pressure air.
- Loose contact will get the contact points hot, so pay attention to the contact points
- Be sure to check if the rated current of the fuse is right when changing it
- Disconnect the wire of the positive pole of the battery for safety when maintenance is done.
- It is not allowed to depress the accelerator hard and frequently, which may shorten the life of the controller.
- It is not necessary to fill the battery with liquids such as battery additives or water.
- Do not drive at high speed when going downhill; slow down the cart when turning and remind the passengers to hold on when turning and going downhill.
- Children are not allowed to play in the car; children should be seated between adults and protected by them when the car is running.



Lubricating the plug and receptacle with the ac cord connected to a power source can cause property damage, electrical shock, serious personal injury, and death. Do not lubricate the plug and vehicle charger receptacle with the ac cord connected to a power source.

CHARGING INSTRUCTIONS

Charging with onboard charger

DANGER

Charging the batteries with accessories on can cause a fire and serious personal injury. Turn off all accessories before charging the batteries.

WARNING

Make sure that all cord connections at the receptacle are clean and tight. Charging the batteries with unapproved accessories or loose cord connections can cause a fire and/or serious personal injury. Turn off the cart and all accessories before charging the battery.

We do not recommend charging in extreme cold or extreme heat. The recommended temperature range to charge the battery is from -4°F (-20°C) to 113°F (45°C).

1. Turn the key to OFF.
2. Turn off all accessories.
3. Connect the AC cord (1) to the power source.

Note: The vehicle will start to charge in 2 to 10 seconds.

CAUTION

1. Operate the vehicle only from the driver's seat.
2. Do not operate in inclines above 25 degrees.
3. Only an authorized licensed driver can operate the vehicle.
4. Only operate the vehicle in compliance with local and state laws and designated areas.
5. Use caution when operating the vehicle in the presence of higher-speed vehicles, in congested areas, or on unimproved or uneven



Vehicle Operation

DANGER

1. Operating the vehicle while occupants are not fully seated can cause serious personal injury or death. Start the vehicle only when all occupants are fully seated.
2. Falling objects can cause property damage, serious personal injury, or death. Do not operate the vehicle where there is a risk of falling objects.
3. Do not let a passenger hold a child on their lap while the vehicle is in operation.
4. Do not let passengers ride in the vehicle or trailer while being towed.

WARNING

1. Keep away from drop-offs, steep slopes, and unstable surfaces.
2. Sudden starts, stops, and turns can cause property damage and serious personal injury. Prevent sudden starts, stops, and turns.
3. Failure to correctly maintain the vehicle and make necessary repairs can decrease vehicle performance, cause a fire, property damage, serious personal injury, or death. If problems are found during scheduled inspection or service, operate the vehicle only when repairs are made.
4. Make sure that all passengers can secure themselves in the vehicle before vehicle operation.
5. To prevent serious personal injury, keep entire body in the vehicle during operation.
6. The vehicle is not specially equipped for handicapped persons. Before vehicle operation, make sure that all persons comply with the warnings and operating instructions.
7. Incorrect operation of the vehicle can cause decreased vehicle performance, property damage, serious personal injury, or death.
8. To prevent falls from the vehicle, passengers must stay seated and always hold on to hand holds or handrails when the vehicle is in operation. The driver must keep both hands on the steering wheel when the vehicle is in operation.
9. A sharp turn at high speeds can cause a roll-over, fall, property damage, and serious personal injury. Operate the vehicle slowly in turns.
10. Serious personal injury or death may occur when vehicle is incorrectly used and operated. Before leaving the vehicle or during vehicle maintenance, disable the vehicle.
11. The vehicle is not designed to meet child safety seat compatibility requirements. Children requiring a child safety seat must not ride on the vehicle. Comply with state and local laws pertaining to child safety.
12. This vehicle is not intended for use by persons, including children, with reduced physical, sensory, or mental capabilities, or lack of experience and knowledge, unless they have been given supervision or instruction concerning use of the vehicle by a person responsible for their safety. Children should be supervised to ensure that they do not play with the vehicle.

DAILY PRE-OPERATIONAL SAFETY AND PERFORMANCE CHECKS

OVERVIEW

Use the daily pre-operational checklist and vehicle performance inspection to inspect the operational condition and performance of the vehicle.

If a vehicle is found to be in bad operational condition, remove it from operation. Removal from operation will prevent more damage to the vehicle and prevent a serious injury.

If the vehicle is removed from operation, speak with your dealer or distributor for maintenance and repairs.

INSPECTION AREA	INSPECTION CRITERIA
General	<ul style="list-style-type: none"> • Make sure that all parts are correctly installed. • Make sure that all nuts, bolts, and screws are tight. • Replace missing, worn, or damaged items.
Decals	<ul style="list-style-type: none"> • Make sure all safety, regulatory, and marketing decals are correctly installed. • Clean the decals with a soft damp cloth. • Replace missing, worn, or damaged decals.
Tires	<ul style="list-style-type: none"> • Examine for wear and damage. • Replace worn or damaged tires. • Make sure that the tire pressure is correct.
Battery	<ul style="list-style-type: none"> • Make sure that the battery is fully charged. • Replace missing, worn, or damaged items.
Battery Charger	<ul style="list-style-type: none"> • Examine the electrical cords for cracks, loose connections, and frayed wires. • Examine receptacle contacts and plug terminals. Clean as necessary. • Replace missing, worn, or damaged items. • Make sure that the battery charger operates correctly.
Vehicle Performance Inspection	<ul style="list-style-type: none"> • Do a vehicle performance inspection.

RULES OF SAFE OPERATION

For safe operation, the driver should have a good knowledge of the operation system of both the car and its features, abide by local laws and regulations, and obey the following rules:

1. If the cart is overloaded, the motor will be damaged, the cart will lose control, and the cart and the battery life will be shortened.
2. Don't let unqualified people drive the cart.
3. Don't make the cart climb hills in unsafe conditions.
4. Don't overtake other vehicles at crossroads, and blind areas, or in other dangerous zones.

VEHICLE PERFORMANCE INSPECTION

Before the vehicle performance inspection:

- Read and obey all safety decals and information located on the vehicle.
- Understand how to operate the vehicle correctly and safely.
- Understand the function of all vehicle controls, indicators, displays, and gauges.
- Ensure the front wheels are turned in the direction of travel.
- No obstructions are in the vehicle's path.

DURING THE VEHICLE PERFORMANCE INSPECTION:

- Listen for unusual noises such as squeaks or rattles.
- Examine the ride and performance of the vehicle.
- Examine the steering. The vehicle must be easy to steer and must not have play in the steering wheel.
- The vehicle must stop smooth and straight. The brake pedal must not be able to be pushed to the floorboard. Have a trained technician do a brake system check if:
 - The vehicle swerves.
 - The brake pedal goes more than half the distance to the floorboard with moderate pressure applied.
 - The vehicle does not stop.

TO DO THE VEHICLE PERFORMANCE INSPECTION:

1. Turn the key to ON.
2. Push and hold the brake pedal.
3. Set the Forward / Neutral / Reverse control to Reverse. Make sure that the multi-purpose buzzer operates.
4. Release the brake pedal.
5. Slowly push the accelerator pedal. Make sure the vehicle moves in reverse.
6. Slowly push the brake pedal. Stop the vehicle.
7. Set the FNR to Forward. Make sure that the multi-purpose buzzer does not operate.
8. Release the brake pedal.
9. Slowly push the accelerator pedal. Make sure that the vehicle moves forward.
10. Operate the vehicle to full speed.
11. Release the accelerator pedal. Make sure:
 - a. The accelerator pedal goes back to its initial position.
12. Slowly push the brake pedal. Stop the vehicle.
13. Park the vehicle on a level surface.
14. Engage the parking brake.

MOTOR START

BEFORE STARTING CART:

- Read and obey all safety decals and information located on the vehicle.
- Understand how to operate the vehicle correctly and safely.
- Understand the function of all vehicle controls, indicators, displays, and gauges.
- Make sure that all passengers are seated and use the hand holds or handrails. The operator must have both hands on the steering wheel.
- Front wheels are turned in the direction of travel.
- No obstructions are in the vehicle's path.
- Forward / Neutral / Reverse control (FNR) is set to N.
- The park brake is set.
- The accelerator pedal is not pushed.
- The vehicle is at a full stop.



PUSH START THE MOTOR:

1. Before you Push the IGNITION BUTTON, be sure the KEY is within 1 foot from the IGNITION BUTTON to operate.
2. Push the IGNITION BUTTON to start the motor.

TURN OFF MOTOR

1. Release the accelerator pedal.
2. Stop the vehicle.
3. Push and hold the brake pedal.
4. Set the Forward / Neutral / Reverse control (FNR) to N.
5. Press the IGNITION BUTTON to turn the cart OFF.
6. Engage the park brake to lock the wheels.
7. Remove the key. Keep the key in a safe area.

VEHICLE MAINTENANCE

ELECTRONIC MOTOR:

- Idle running of the motor should be avoided.
- Keep away from gas fumes and other potentially flammable gases and substances.
- Remove mud, sand, and other clinging objects often so as to prevent overheating.
- Periodically use low pressure air to remove the dust from the carbon brush and the commutator.

TROUBLESHOOTING GUIDE:

CONTROLLER

Maintenance of speed controller: the speed controller of the car is wholly imported and characterized with controlling the running speed, torque, and Brake smoothly with no noise, high efficiency, and little energy by adopting the technology of high-frequency MOS.

Regular Maintenance:

1. Check if the connection between contacts are in good condition, if any contact sticks or is jammed, and if any traveling contact is in a mechanical Deadlock.
2. Check if the changeover switch can be switched on and off properly.

Note: These checks should all be performed after the battery is cut off. The above checks shall be carried out once every 3 months: after turning off the power key, the filter capacitor in the controller power unit shall keep discharging for a few more minutes: don't wash the electrical parts with water. Remove dust with a brush or high-pressure air. For questions contact care@vcarts.com

TROUBLESHOOTING GUIDE

SYMPTOM(S)	POSSIBLE CAUSE(S)
The cart will not start.	<p>A. The controller has not been connected to the power.</p> <ul style="list-style-type: none"> i. malfunctioning battery or wire connectors, ii. the fuse of power connection is blown. iii. the resistance is broken upon charging. <p>B. No signal has been transmitted to the controller:</p> <ul style="list-style-type: none"> i. power is damaged or any connection wires of it disconnect, ii. the accelerator of the pedal is damaged, iii. malfunctioning acceleration pedal, iv. break off or short circuit of the polarity diode v. the green wire connecting the acceleration pedal and the electrically controlled KSI terminal connector is not working properly. <p>C. The main connectors stick or have short-circuited</p> <p>D. The controller of the motor is damaged,</p> <p>E. Any open of the connection of excitation coil or any open of the excitation coil</p>
The maximum speed declines.	<p>A. The battery will be used up soon.</p> <p>B. The acceleration pedal is malfunctioning</p> <p>C. The controller is malfunctioning</p>

BRAKE SYSTEM

Effective brake force is around 65 lbs. of force. The distance to step down the breaking pedal is not more than two-thirds of the overall stepping down distance of the braking pedal.

Effective parking force is around (200 N) 45 lbs. of force. When the parking pedal is released to its free position, the parking function is released.

Pressing down on the front of the brake until it clicks, locks the brake. When pressed down again the bake lock will release.

LUBRICATION

Lubrication points:

1. Steering gears

USER SHOULD DO MAINTENANCE AS FOLLOWS SINCE PERFORMANCE OF THE CAR AND LIFE OF THE BATTERY GREATLY DEPEND ON IT:

1. The exterior of the battery should always be kept clean and dry.
2. The connection of the battery must be in good condition.
3. Recharge the same day, the battery should not be left discharged. If left discharged the life of the battery will be impacted.
4. Do not introduce impurities into the battery. Keep the outside of the battery clean. Do not open battery case.
5. Keep an eye on the indication of electricity meter when driving.
6. The driver should estimate the life of the battery and mileage traveled to return to the recharge station before battery discharges fully (over discharges). If the battery over discharges, its life will be shortened.
7. If the car is out of use for a long time the battery shall be fully recharged before being put aside, and also shall be fully recharged every half of a month until the charger is off automatically.
8. While battery is recharging, the car should be parked.
9. Make sure the replacement battery has the same voltage, amperage, and current capacity as the original one v3-power lithium-ion batteries are recommended for this model of car.
10. The charging extension cord is sold separately.
11. If the car is out of use for a long time the battery shall be fully recharged before being put aside, but also shall be fully recharged every half of a month until the charger is off automatically.
12. While battery is recharging, the car should be parked and power in the off position.

EXTENDED STORAGE

EXTENDED STORAGE PREPERATION

The recommended extended storage temperature range is from -4°F (-20°C) to 113°F (45°C). To prepare your vehicle for extended storage:

1. Turn off all electronic accessories.
2. Set the Forward / Neutral / Reverse control (FNR) to N.
3. Turn the key to OFF.
4. Remove the key. Keep the key in a safe area.
5. Put chocks against the wheels.
NOTE: DO NOT ENGAGE THE PARKING BRAKE.
6. Remove all cargo and personal items.
7. Keep the vehicle in a cool and dry area.
8. Adjust pressure in each tire to recommended tire pressure.
9. Clean the vehicle.
10. Connect the battery charger.

RETURN TO SERVICE FROM EXTENDED STORAGE

1. Fully charge the battery.
2. Set the Forward / Neutral / Reverse control (FNR) to N.
3. Adjust the pressure in each tire to the recommended tire pressure.
4. Have a trained technician lubricate the vehicle.
5. Do a vehicle performance inspection.

TRANSPORT DISCLAIMER/ INSTRUCTIONS

1. When transporting your cart, whether on a trailer behind a vehicle or in the bed of a pickup, care should be exercised to avoid damage to the roof of the cart. More particularly, the cart roof is designed for speeds of up to 30 miles an hour, so when transporting the cart at regular vehicle highway speeds, the excess wind speed may cause damage to the cart roof.
2. To prevent or reduce damage to the cart roof, VCards® recommends that the roof be secured by a strap extended from the front basket or bumper of the cart, over the roof of the cart lengthwise down the middle of the roof and attaching to the rear bumper or rear seat handle near the middle of the cart. This strap should be tightened so that the front leading edge of the roof on the front of the cart moves downward due to the tightening strap approximately one half of an inch. This strap pushing downward on the front edge of the roof prevents the front edge of the roof from oscillating at high wind speeds, as this oscillation may cause damage to the cart roof.
3. Further, when transporting your cart, it is recommended that the cart be transported in a forward direction, meaning that the cart should be traveling so that the leading edge of the roof on the front of the cart first contacts the oncoming wind behind the vehicle it's being transported on or behind. Further, care should be taken to watch or monitor the leading edge of the roof for oscillation or movement, and if any movement is detected the strap over the roof should be immediately tightened further to reduce or prevent roof oscillation.
4. **Damage to the roof of the cart due to improper transport is not covered by warranty.**

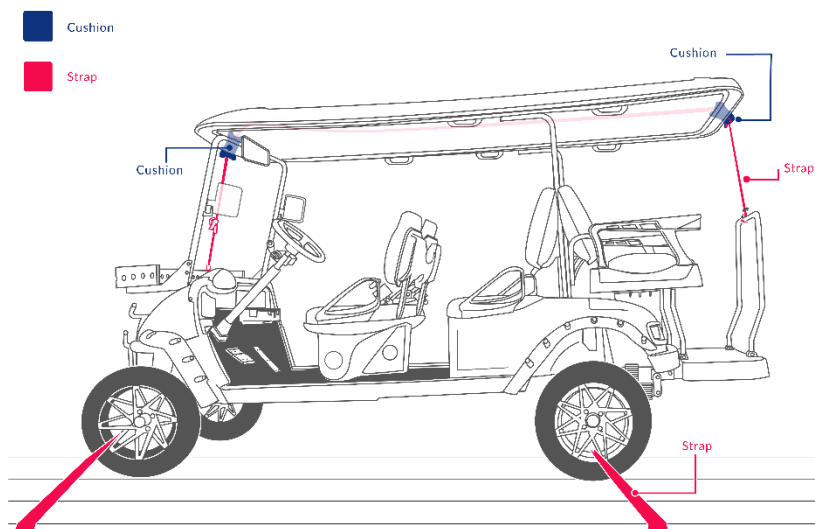

INCLINE DISCLAIMER

1. Carts should NOT be driven over dangerous terrain.
2. Carts should NOT be driven up steep hills or inclines exceeding or equal to 20°.

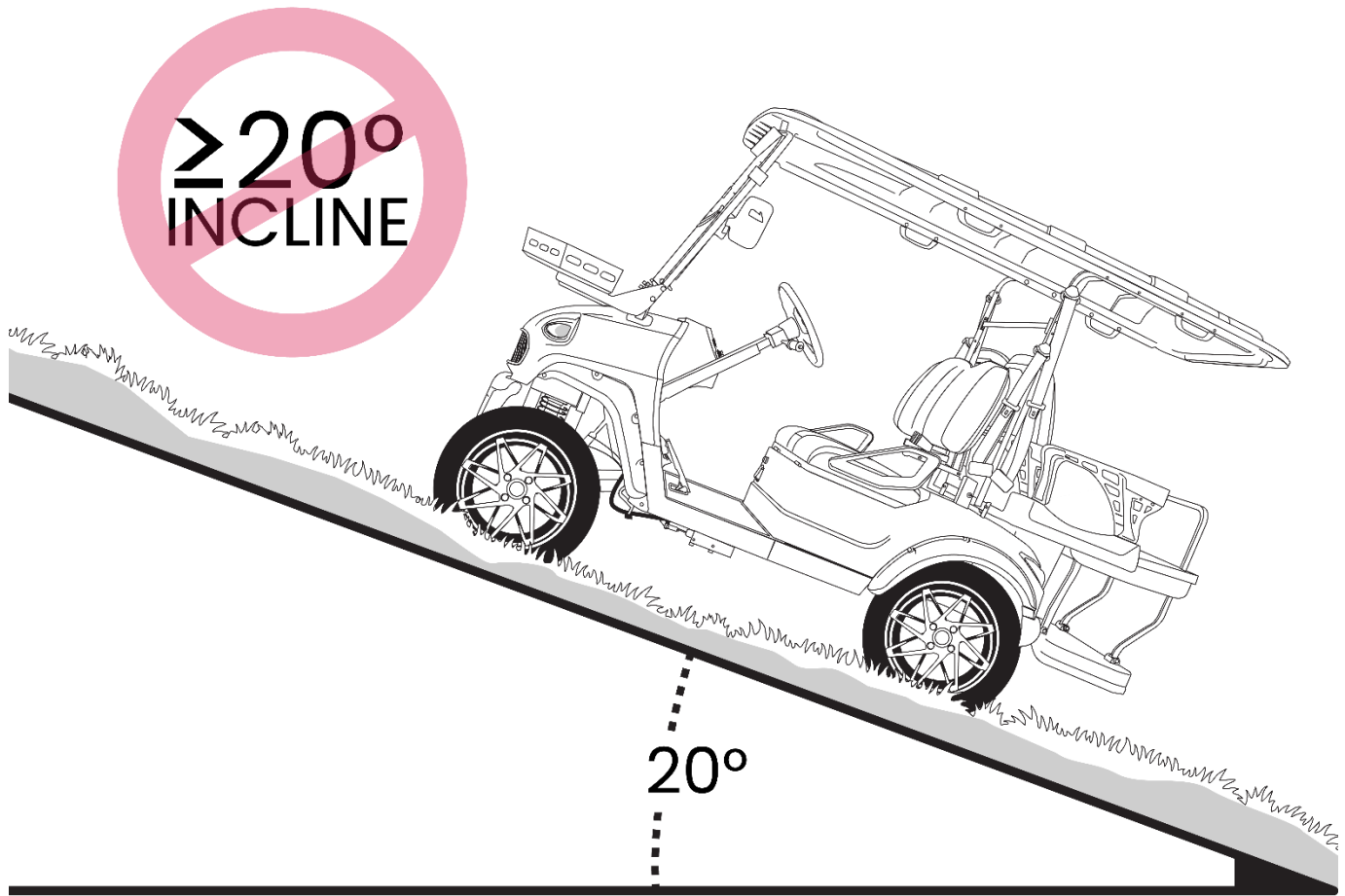

WARNING

If driver attempts inclines or angles over or equal to 20-degrees loss of power may occur.

